

ELECTRIC VIBRATORS FOR INDUSTRIAL USE - MVSI S90

6 POLES - 1000/1200 RPM

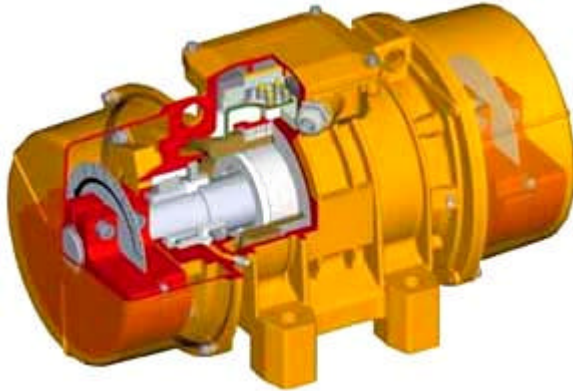

DIMENSIONAL SPECIFICATIONS (mm)

TYPE	SIZE	CSA	Static moment kgmm		Centrifugal force Kg kN				Weight kg		Max. input power W		Max. current A		Ia/In	
			50Hz	60Hz	50Hz	60Hz	50Hz	60Hz	50Hz	60Hz	50Hz	60Hz	50Hz 380V	60Hz 460V	50Hz	60Hz
MVSI 10/40-S90	10	°	30.1	30.1	35	49	0.331	0.476	8.3	8.3	120	135	0.3	0.3	1.9	2.07
MVSI 10/100-S90	10	°	84.2	84.2	94.3	136	0.925	1.33	10.7	10.7	120	135	0.3	0.3	1.9	2.07
MVSI 10/200-S90	20	°	163	163	183	264	1.8	2.59	16.9	16.9	185	205	0.5	0.5	2.72	3.1
MVSI 10/310-S90	30	°	286	209	321	338	3.15	3.32	23.5	22.2	350	380	0.72	0.68	2.63	2.79
MVSI 10/550-S90	35	°	457	457	512	737	5.02	7.23	36.5	36.5	350	380	0.75	0.68	2.53	3.68
MVSI 10/810-S90	40	°	723	561	809	905	7.94	8.88	54	52.6	680	760	1.4	1.35	2.79	3.33
MVSI 10/1110-S90	50	°	1012	715	1132	1151	11.1	11.3	67	59.5	750	750	1.65	1.5	3.33	4.13
MVSI 10/1400-S90	50	-	1274	904	1424	1455	14	14.3	78	71	950	1000	2.1	2	3.6	4.3
MVSI 10/1610-S90	60	°	1464	962	1638	1549	16.1	15.2	94	83	1100	1300	2.2	2.2	4.21	4.05
MVSI 10/1800-S90	60	-	1608	1087	1800	1750	17.7	17.2	99	87						
MVSI 10/2100-S90	60	-	1927	1318	2154	2121	21.1	20.8	105	93	1500	1700	3	2.9	4.5	4.2
MVSI 10/2610-S90	70	°	2326	1706	2601	2747	25.5	26.9	130	116	1960	2100	4.1	3.75	5.35	5.6
MVSI 10/3000-S90	70	-	2690	1940	3007	3124	29.5	30.6	145	130	2200	2400	4.5	4.3	4.35	4.81
MVSI 10/3810-S90	80	°	3422	2380	3826	3831	37.5	37.6	188	170	2500	3000	5.1	5	5.91	6
MVSI 10/4700-S90	80	-	4206	2887	4701	4648	46.1	46	204	183	3200	3600	6.5	6	5.24	5.5
MVSI 10/5200-S90	90	°	4658	3288	5208	5293	51.1	51.9	238	215	3800	4000	7	6.5	4.71	5.08
MVSI 10/5600-S90	90	-	5010	3480	5600	5600	54.9	54.9	248	230						
MVSI 10/6500-S90	90	°	5838	4055	6527	6529	64	64	268	258	4300	5000	8.2	8.1	4.51	5.83
MVSI 10/6600-S90**	97	-	6083	3979	6799	6405	66.7	62.8	285	257	5000	5900	10	9.8	5.61	5.82
MVSI 10/7000-S90	95	-	6250	4348	7000	7000	68.7	68.7	305	270						
MVSI 10/8000-S90	95	-	7197	4967	8046	7996	78.9	78.4	320	282	7000	7500	9.6	13	4.59	5.58
MVSI 10/9000-S90	95	-	7752	5385	8666	8669	85	85	326	289	7500	8200	14	12.9	4.13	4.88
MVSI 10/10000-S90	97	-	8673	5664	9695	9117	95.1	89.4	381	340	7600	8000	13.5	12.4	4.72	4.92
MVSI 10/11600-S90	97	-	10089	6830	11300	11000	111	108	400	360						
MVSI 10/12000-S90**	100	-	10996	7543	12294	12141	119	119	500	445	9000	9500	16.3	15	5.21	5.73
MVSI 10/13000-S90	97	-	11510	7329	12867	11800	126	122	420	382	9600	10000	17	16	4.98	5
MVSI 10/15000-S90**	105	-	12662	8700	14155	14004	139	137	643	605	10600	11270	19	18	5.88	5.78
MVSI 10/15600-S90	100	-	13400	9320	15000	14500	147	147	540	490	10600	11270	19	18	5.88	5.78
MVSI 10/17500-S90	105	-	15500	10439	17327	16804	170	165	705	656	13000	13700	24.5	23	5.71	5.96
MVSI 10/22000-S90	110	-	20025	12553	22386	20208	220	198	926	896	19000	19000	33	25.5	4.67	5.88

ELECTRIC VIBRATORS FOR INDUSTRIAL USE - MVSI S90

6 POLES - 1000/1200 RPM

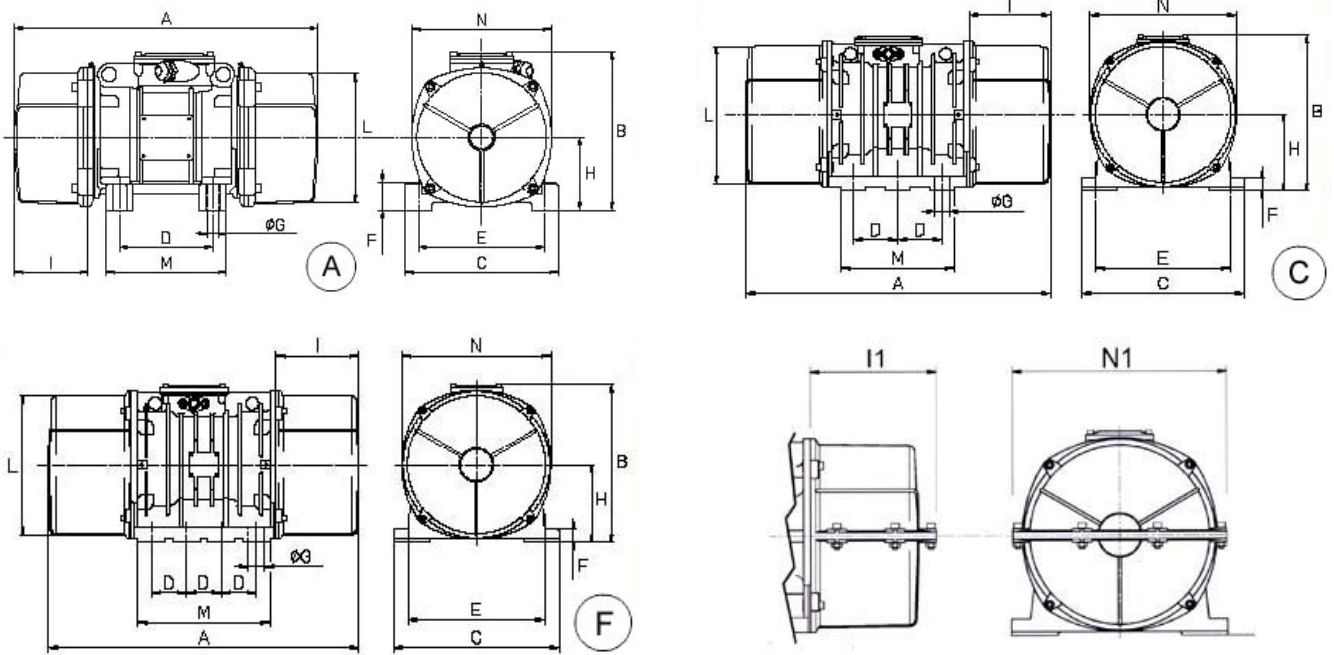

Type	Figure	A 50Hz	A 60Hz	B	C	D	E	ØG	N°	F	H	I 50Hz	I 60Hz	L	M	N	1 or 2 split covers I1 N1	Cable entry thread	
MVSI 10/40-S90	A	245	245	181	152	90	125	13	4	29.5	73	47	47	127	117	135	-	-	PG13.5
MVSI 10/100-S90	A	298	298	181	152	90	125	13	4	29.5	73	75	75	127	117	135	-	-	PG13.5
MVSI 10/200-S90	A	345	345	198	167	105	140	13	4	28.5	80	90	90	146	137	153	-	-	PG16
MVSI 10/310-S90	A	381	381	210	205	120	170	17	4	45	91.5	88	88	168	160	178	-	-	PG16
MVSI 10/550-S90	A	435	435	233	205	120	170	17	4	54	104.5	117.5	117.5	187	162	203	-	-	PG16
MVSI 10/810-S90	A	500	448	246	230	140	190	17	4	54	116	134	108	210	180	225	-	-	PG16
MVSI 10/1110-S90	A	568	500	246	230	140	190	17	4	54	116	168	134	210	180	225	-	-	PG16
MVSI 10/1400-S90	A	608	608	246	230	140	190	17	4	54	116	188	188	210	180	225	-	-	PG16
MVSI 10/1610-S90	A	617	537	273	278	155	225	22	4	72	133	177	137	238	205	253	-	-	PG16
MVSI 10/1800-S90	A																		
MVSI 10/2100-S90	A	617	537	273	278	155	225	22	4	72	133	177	137	238	205	253	-	-	PG16
MVSI 10/2610-S90	A	666	666	333	310	155	255	23.5	4	77	157	178	178	277	215	295	-	-	PG21
MVSI 10/3000-S90	A	706	706	333	310	155	255	23.5	4	77	157	198	198	277	215	295	-	-	PG21
MVSI 10/3810-S90	A	730	730	360	340	180	280	26	4	80	165	200	200	305	240	320	226	356	PG21
MVSI 10/4700-S90	A	796	796	360	340	180	280	26	4	80	165	233	233	305	240	320	259	356	PG21
MVSI 10/5200-S90	A	740	740	370	390	200	320	28	4	90	180	190	190	330	270	350	266	382	PG21
MVSI 10/5600-S90	A																		
MVSI 10/6500-S90	A	840	840	370	390	200	320	28	4	90	180	240	240	330	270	350	266	382	PG21
MVSI 10/6600-S90**	C	750	750	436	460	125	380	38	6	35	215	174	174	387	320	414	-	-	1 inch GAS°
MVSI 10/7000-S90	A																		
MVSI 10/8000-S90	A	870	870	395	392	200	320	28	4	100	192	255	255	355	270	375	280	410	PG21
MVSI 10/9000-S90	A	870	870	395	392	200	320	28	4	100	192	255	255	355	270	375	280	410	PG21
MVSI 10/10000-S90	C	862	862	436	460	125	380	38	6	35	215	230	230	387	320	414	246	450	1 inch GAS°
MVSI 10/11600-S90	C																		
MVSI 10/12000-S90**	C	990	990	454	530	140	440	45	6	38	230	240	240	420	370	448	-	-	1 inch GAS°
MVSI 10/13000-S90	C	1002	1002	436	460	125	380	38	6	35	215	300	300	387	320	414	-	-	1 inch GAS°
MVSI 10/15000-S90**	F	960	960	526	570	140	480	45	8	41	268	200	200	495	510	516	270	566	1 inch GAS°
MVSI 10/15600-S90	C																		
MVSI 10/17500-S90	F	1040	1040	526	570	140	480	45	8	41	268	240	240	495	510	516	270	566	1 inch GAS°
MVSI 10/22000-S90	F	1150	1150	607	610	140	520	45	8	38	297	297.5	297.5	542	510	582	-	-	1 inch GAS°